

Паттерны шевронов - производство ARTEGO SA Румыния

CHEVRON R15

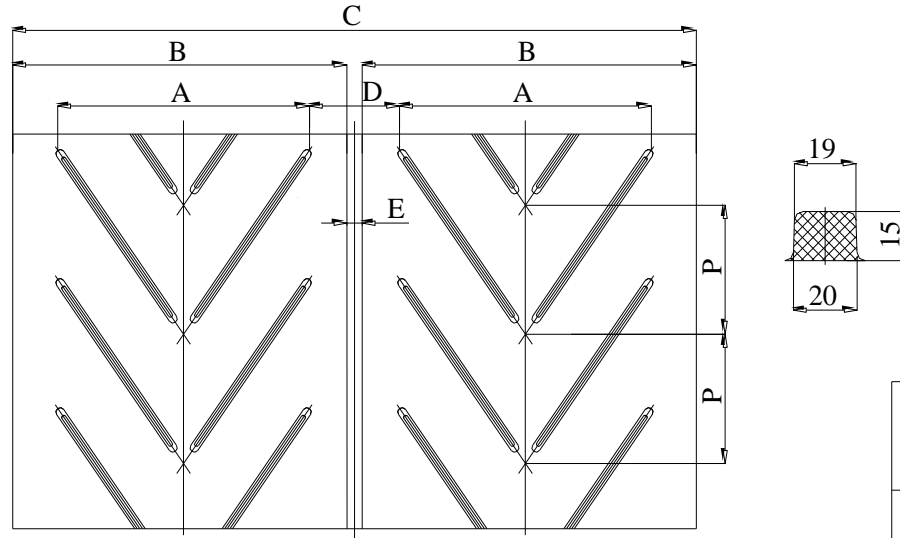

Type	C [mm]	B [mm]	A [mm]	P [mm]	D [mm]	E [mm]
Chevron R15/287	1000 - 1600	400	287	145	413	300
Chevron R15/287	1000 - 1600	450	287	145	413	250
Chevron R15/287	1000 - 1600	500	287	145	413	200
Chevron R15/436	1200 - 1600	500	436	218	424;364;264	360;300;200
Chevron R15/436	1200 - 1600	550	436	218	424;364;264	310;250;150
Chevron R15/436	1200 - 1600	600	436	218	424;364;264	260;200;100
Chevron R15/436	1200 - 1600	650	436	218	424;364;264	210;150; 50
Chevron R15/436	1200 - 1600	700	436	218	424;364;264	160;100; 0
Chevron R15/436	1200 - 1600	750	436	218	424;364	110; 50
Chevron R15/436	1200 - 1600	800	436	218	424;364	60; 0
Chevron R15/585	1400 - 1600	650	585	295	215	150
Chevron R15/585	1400 - 1600	700	585	295	215	100
Chevron R15/585	1400 - 1600	750	585	295	215	50
Chevron R15/585	1400 - 1600	800	585	295	215	0

Rubber mixture, properties for covers	General use				Resistance to temperature		Resistance to oil		
	w	x	y	z	T2	T3	MOR	G	ROS
Tensile strength, daN/cm ² , min	180	250	200	150	150	120	150	140	150
Elongation at break, % min	400	450	400	70	450	350	350	350	350
Abrasion resistance (volume of wear), mm ³ , max	90	120	150	250	150	200	200	200	150
Resistant to oil	No	No	No	No	No	No	Medium	Good	Very good
Working temperature, °C [max]	70	70	70	70	120	150	70	80	100

Characteristics of insertions

Type of insertions	EP 80	EP 100	EP 125	EP 160
Insertions number	2 - 4			
Tensile strength, Kgf/cm, min	160 - 240	200 - 400	250 - 500	315 - 630
Width [mm]	1000 - 1600			
Thickness [mm]	4 - 12	6 - 12	6 - 12	6 - 12

Паттерны шевронов - производство ARTEGO SA Румыния

CHEVRON R15

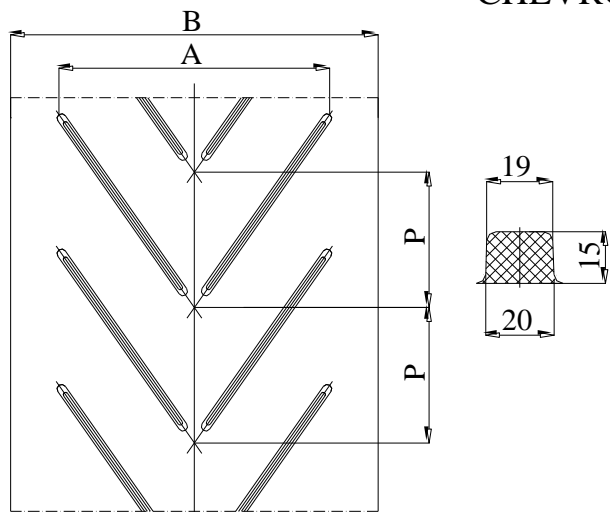

Type	B [mm]	A [mm]	P [mm]
Chevron R15/287	400	287	145
Chevron R15/287	450	287	145
Chevron R15/287	500	287	145
Chevron R15/436	500	436	218
Chevron R15/436	550	436	218
Chevron R15/436	600	436	218
Chevron R15/436	650	436	218
Chevron R15/436	700	436	218
Chevron R15/436	750	436	218
Chevron R15/436	800	436	218
Chevron R15/585	650	585	295
Chevron R15/585	700	585	295
Chevron R15/585	750	585	295
Chevron R15/585	800	585	295

Rubber mixture, properties for covers	General use				Resistance to temperature		Resistance to oil		
	w	x	y	z	T2	T3	MOR	G	ROS
Tensile strength, daN/cm ² , min	180	250	200	150	150	120	150	140	150
Elongation at break, %, min	400	450	400	70	450	350	350	350	350
Abrasion resistance (volume of wear), mm ³ , max	90	120	150	250	150	200	200	200	150
Resistant to oil	No	No	No	No	No	No	Medium	Good	Very good
Working temperature, °C [max]	70	70	70	70	120	150	70	80	100

Characteristics of insertions

Type of insertions	EP 80	EP 100	EP 125	EP 160
Insertions number	2 - 4			
Tensile strength, Kgf/cm, min	160 - 240	200 - 400	250 - 500	315 - 630
Width [mm]	400 - 800			
Thickness [mm]	4 - 12	6 - 12	6 - 12	6 - 12

CHEVRON R15

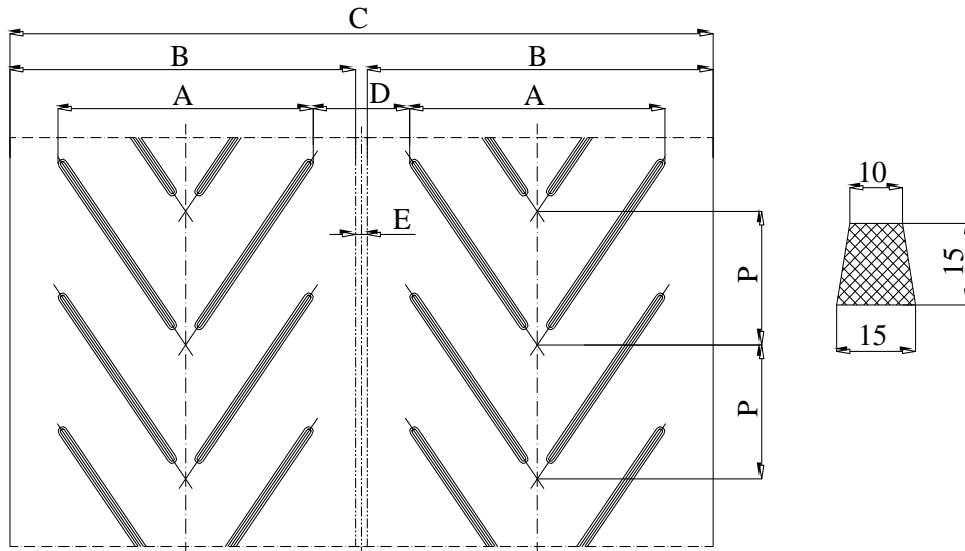

Type	C [mm]	B [mm]	A [mm]	P [mm]	D [mm]	E [mm]
Chevron R15/385	1200-1600	400	385	254	415	400
Chevron R15/385	1200-1600	450	385	254	415	350
Chevron R15/385	1200-1600	500	385	254	415	300
Chevron R15/385	1200-1600	550	385	254	415	250
Chevron R15/385	1200-1600	600	385	254	415	200
Chevron R15/385	1200-1600	650	385	254	415	150
Chevron R15/385	1200-1600	700	385	254	415	100
Chevron R15/385	1200-1600	750	385	254	415	50
Chevron R15/385	1200-1600	800	385	254	415	0

Rubber mixture, properties for covers	General use				Resistance to temperature		Resistance to oil		
	w	x	y	z	T2	T3	MOR	G	ROS
Tensile strength, daN/cm ² , min	180	250	200	150	150	120	150	140	150
Elongation at break, % min	400	450	400	70	450	350	350	350	350
Abrasion resistance (volume of wear), mm ³ , max	90	120	150	250	150	200	200	200	150
Resistant to oil	No	No	No	No	No	No	Medium	Good	Very good
Working temperature, °C [max]	70	70	70	70	120	150	70	80	100

Characteristics of insertions

Type of insertions	EP 80	EP 100	EP 125	EP 160
Insertions number	2 - 4			
Tensile strength, Kgf/cm, min	160 - 240	200 - 400	250 - 500	315 - 630
Width [mm]	1200 - 1600			
Thickness [mm]	4 - 12	6 - 12	6 - 12	6 - 12

CHEVRON R15

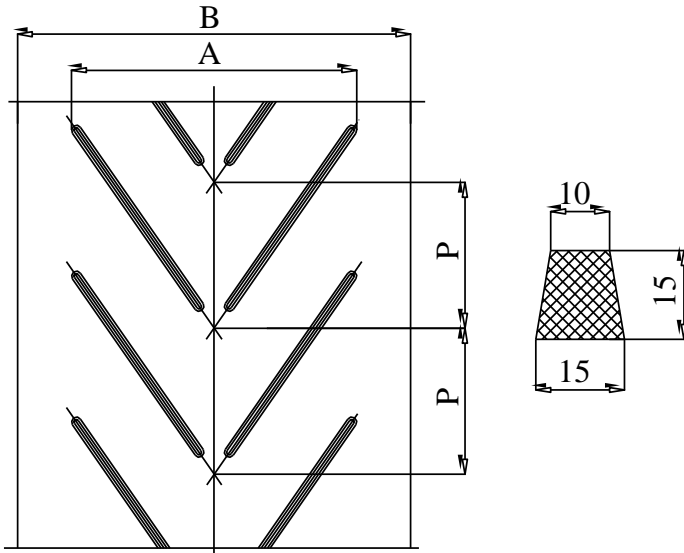

Type	B [mm]	A [mm]	P [mm]
Chevron R15/385	400	385	254
Chevron R15/385	450	385	254
Chevron R15/385	500	385	254
Chevron R15/385	550	385	254
Chevron R15/385	600	385	254
Chevron R15/385	650	385	254
Chevron R15/385	700	385	254
Chevron R15/385	750	385	254
Chevron R15/385	800	385	254

Rubber mixture, properties for covers	General use				Resistance to temperature		Resistance to oil		
	w	x	y	z	T2	T3	MOR	G	ROS
Tensile strength, daN/cm ² , min	180	250	200	150	150	120	150	140	150
Elongation at break, % min	400	450	400	70	450	350	350	350	350
Abrasion resistance (volume of wear), mm ³ , max	90	120	150	250	150	200	200	200	150
Resistant to oil	No	No	No	No	No	No	Medium	Good	Very good
Working temperature, °C [max]	70	70	70	70	120	150	70	80	100

Characteristics of insertions

Type of insertions	EP 80	EP 100	EP 125	EP 160
Insertions number	2 - 4			
Tensile strength, Kg/cm, min	160 - 240	200 - 400	250 - 500	315 - 630
Width [mm]	400 - 800			
Thickness [mm]	4 - 12	6 - 12	6 - 12	6 - 12

CHEVRON R25

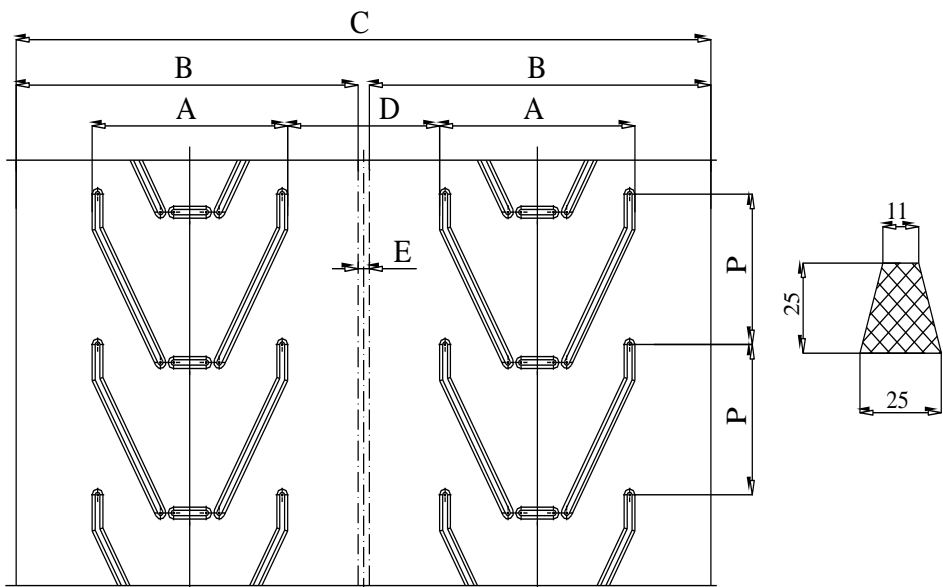

Rubber mixture, properties for covers	General use				Resistance to temperature		Resistance to oil		
	w	x	y	z	T2	T3	MOR	G	ROS
Tensile strength, daN/cm ² , min	180	250	200	150	150	120	150	140	150
Elongation at break, % min	400	450	400	70	450	350	350	350	350
Abrasion resistance (volume of wear), mm ³ , max	90	120	150	250	150	200	200	200	150
Resistant to oil	No	No	No	No	No	No	Medium	Good	Very good
Working temperature, °C [max]	70	70	70	70	120	150	70	80	100

Type	C [mm]	B [mm]	A [mm]	P [mm]	D [mm]	E [mm]
Chevron R25/450	1250-1600	500	450	312,5	350	300
Chevron R25/450	1250-1600	550	450	312,5	350	250
Chevron R25/450	1250-1600	600	450	312,5	350	200
Chevron R25/450	1250-1600	650	450	312,5	350	150
Chevron R25/450	1250-1600	700	450	312,5	350	100
Chevron R25/450	1250-1600	750	450	312,5	350	50
Chevron R25/450	1250-1600	800	450	312,5	350	0

Characteristics of insertions

Type of insertions	EP 80	EP 100	EP 125	EP 160
Insertions number	2 - 4			
Tensile strength, Kg/cm, min	160 - 240	200 - 400	250 - 500	315 - 630
Width [mm]	1250 - 1600			
Thickness [mm]	4 - 12	6 - 12	6 - 12	6 - 12

Паттерны шевронов - производство ARTEGO SA Румыния

CHEVRON R25

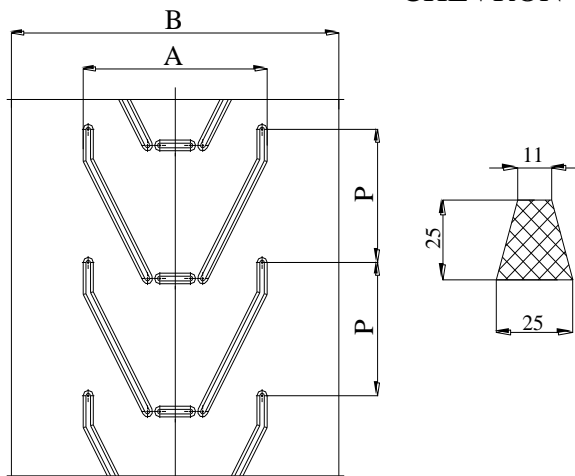

Type	B [mm]	A [mm]	P [mm]
Chevron R25/450	500	450	312,5
Chevron R25/450	550	450	312,5
Chevron R25/450	600	450	312,5
Chevron R25/450	650	450	312,5
Chevron R25/450	700	450	312,5
Chevron R25/450	750	450	312,5
Chevron R25/450	800	450	312,5
Chevron R25/750	800	750	451
Chevron R25/750	850	750	451
Chevron R25/750	900	750	451
Chevron R25/750	950	750	451
Chevron R25/750	1000	750	451
Chevron R25/750	1050	750	451
Chevron R25/750	1100	750	451
Chevron R25/750	1150	750	451
Chevron R25/750	1200	750	451
Chevron R25/750	1250	750	451
Chevron R25/750	1300	750	451
Chevron R25/750	1350	750	451
Chevron R25/750	1400	750	451
Chevron R25/750	1450	750	451
Chevron R25/750	1500	750	451
Chevron R25/750	1550	750	451
Chevron R25/750	1600	750	451

Rubber mixture, properties for covers	General use				Resistance to temperature		Resistance to oil		
	w	x	y	z	T2	T3	MOR	G	ROS
Tensile strength, daN/cm ² , min	180	250	200	150	150	120	150	140	150
Elongation at break, %, min	400	450	400	70	450	350	350	350	350
Abrasion resistance (volume of wear), mm ³ , max	90	120	150	250	150	200	200	200	150
Resistant to oil	No	No	No	No	No	No	Medium	Good	Very good
Working temperature, °C [max]	70	70	70	70	120	150	70	80	100

Characteristics of insertions

Type of insertions	EP 80	EP 100	EP 125	EP 160
Insertions number	2 - 4			
Tensile strength, Kg/cm, min	160 - 240	200 - 400	250 - 500	315 - 630
Width [mm]	500 - 1600 6			
Thickness [mm]	4 - 12	6 - 12	6 - 12	6 - 12

Паттерны шевронов - производство ARTEGO SA Румыния

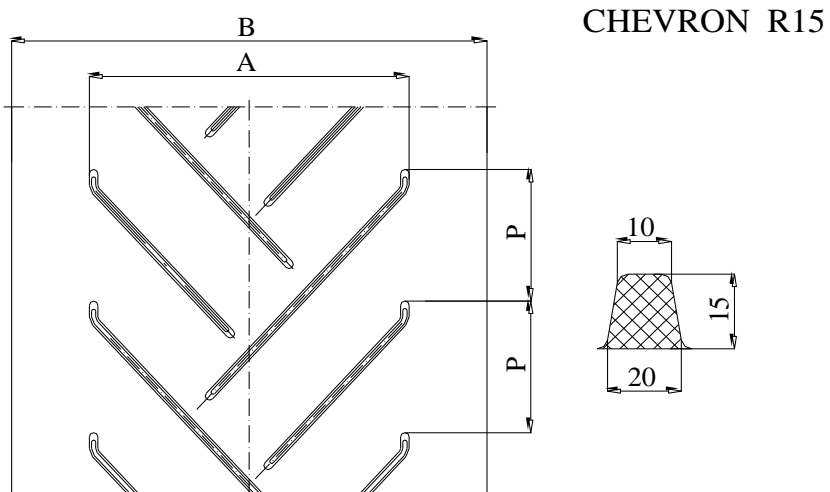

CHEVRON R15

Type	B [mm]	A [mm]	P [mm]
Chevron R15/750	800	750	317
Chevron R15/750	850	750	317
Chevron R15/750	900	750	317
Chevron R15/750	950	750	317
Chevron R15/750	1000	750	317
Chevron R15/750	1050	750	317
Chevron R15/750	1100	750	317
Chevron R15/750	1150	750	317
Chevron R15/750	1200	750	317
Chevron R15/750	1250	750	317
Chevron R15/750	1300	750	317
Chevron R15/750	1350	750	317
Chevron R15/750	1400	750	317
Chevron R15/750	1450	750	317
Chevron R15/750	1500	750	317
Chevron R15/750	1550	750	317
Chevron R15/750	1600	750	317

Rubber mixture, properties for covers	General use				Resistance to temperature		Resistance to oil		
	w	x	y	z	T2	T3	MOR	G	ROS
Tensile strength, daN/cm ² , min	180	250	200	150	150	120	150	140	150
Elongation at break, %, min	400	450	400	70	450	350	350	350	350
Abrasion resistance (volume of wear), mm ³ , max	90	120	150	250	150	200	200	200	150
Resistant to oil	No	No	No	No	No	No	Medium	Good	Very good
Working temperature, °C [max]	70	70	70	70	120	150	70	80	100

Characteristics of insertions

Type of insertions	EP 80	EP 100	EP 125	EP 160
Insertions number	2 - 4			
Tensile strength, Kgf/cm, min	160 - 240	200 - 400	250 - 500	315 - 630
Width [mm]	800 - 1600 ⁷			
Thickness [mm]	4 - 12	6 - 12	6 - 12	6 - 12

CHEVRON R15

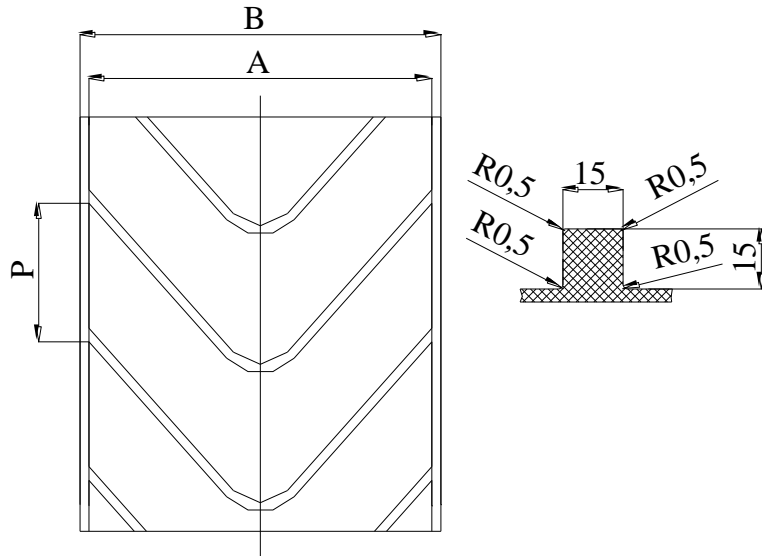

Rubber mixture, properties for covers	General use				Resistance to temperature		Resistance to oil		
	w	x	y	z	T2	T3	MOR	G	ROS
Tensile strength, daN/cm ² , min	180	250	200	150	150	120	150	140	150
Elongation at break, %, min	400	450	400	70	450	350	350	350	350
Abrasion resistance (volume of wear), mm ³ , max	90	120	150	250	150	200	200	200	150
Resistant to oil	No	No	No	No	No	No	Medium	Good	Very good
Working temperature, °C [max]	70	70	70	70	120	150	70	80	100

Characteristics of insertions

Type	B [mm]	A [mm]	P [mm]
Chevron R15/500	500	470	230
Chevron R15/600	600	570	230
Chevron R15/800	800	770	300

Type of insertions	EP 80	EP 100	EP 125	EP 160
Insertions number	2 - 4			
Tensile strength, Kgf/cm, min	160 - 240	200 - 400	250 - 500	315 - 630
Width [mm]	500 - 800			
Thickness [mm]	4 - 12	6 - 12	6 - 12	6 - 12

CHEVRON T-35/G20

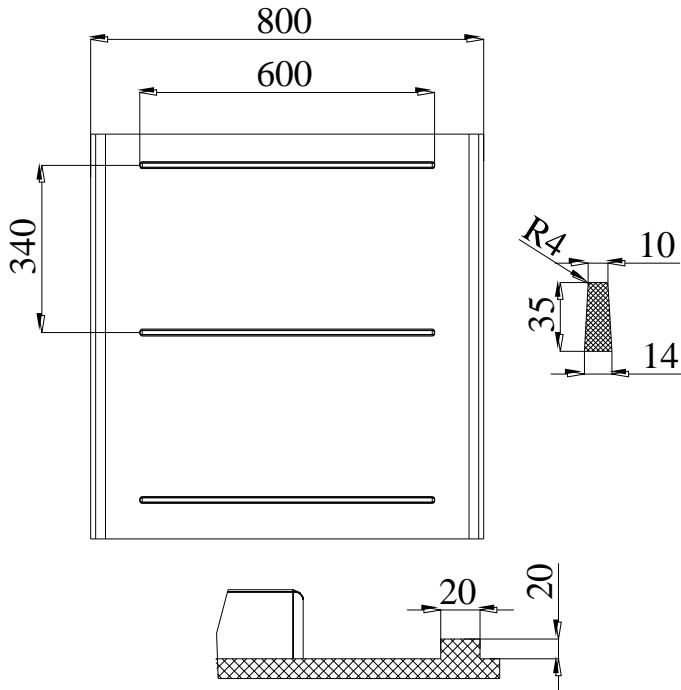

Rubber mixture, properties for covers	General use				Resistance to temperature		Resistance to oil		
	w	x	y	z	T2	T3	MOR	G	ROS
Tensile strength, daN/cm ² , min	180	250	200	150	150	120	150	140	150
Elongation at break, %, min	400	450	400	70	450	350	350	350	350
Abrasion resistance (volume of wear), mm ³ , max	90	120	150	250	150	200	200	200	150
Resistant to oil	No	No	No	No	No	No	Medium	Good	Very good
Working temperature, °C [max]	70	70	70	70	120	150	70	80	100

Characteristics of insertions

Type of insertions	EP 80	EP 100	EP 125	EP 160
Insertions number	2 - 4			
Tensile strength, Kgf/cm, min	160 - 240	200 - 400	250 - 500	315 - 630
Width [mm]	800			
Thickness [mm]	4 - 12	6 - 12	6 - 12	6 - 12

CHEVRON R15

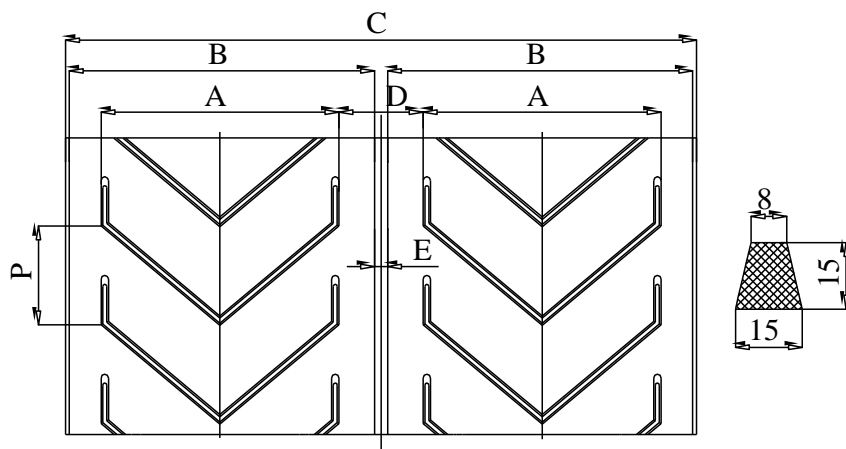

Rubber mixture, properties for covers	General use				Resistance to temperature		Resistance to oil		
	w	x	y	z	T2	T3	MOR	G	ROS
Tensile strength, daN/cm ² , min	180	250	200	150	150	120	150	140	150
Elongation at break, % min	400	450	400	70	450	350	350	350	350
Abrasion resistance (volume of wear), mm ³ , max	90	120	150	250	150	200	200	200	150
Resistant to oil	No	No	No	No	No	No	Medium	Good	Very good
Working temperature, °C [max]	70	70	70	70	120	150	70	80	100

Type	C [mm]	B [mm]	A [mm]	P [mm]	D [mm]	E [mm]
Chevron R15/480	1200-1600	500	480	200	170	150
Chevron R15/480	1200-1600	550	480	200	170	100
Chevron R15/480	1200-1600	600	480	200	170	50
Chevron R15/480	1200-1600	650	480	200	170	0
Chevron R15/650	1500-1600	700	650	200	150	100
Chevron R15/650	1500-1600	750	650	200	150	50
Chevron R15/650	1500-1600	800	650	200	150	0

Characteristics of insertions

Type of insertions	EP 80	EP 100	EP 125	EP 160
Insertions number	2 - 4			
Tensile strength, Kgf/cm, min	160 - 240	200 - 400	250 - 500	315 - 630
Width [mm]	1200 - 1600			
Thickness [mm]	4 - 12	6 - 12	6 - 12	6 - 12

CHEVRON R15

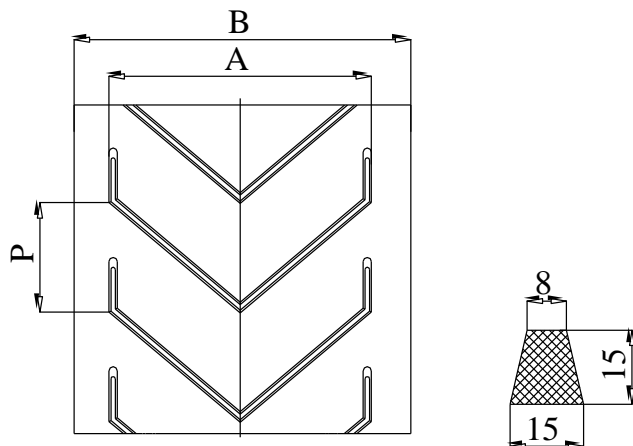

Rubber mixture, properties for covers	General use				Resistance to temperature		Resistance to oil		
	w	x	y	z	T2	T3	MOR	G	ROS
Tensile strength, daN/cm ² , min	180	250	200	150	150	120	150	140	150
Elongation at break, %, min	400	450	400	70	450	350	350	350	350
Abrasion resistance (volume of wear), mm ³ , max	90	120	150	250	150	200	200	200	150
Resistant to oil	No	No	No	No	No	No	Medium	Good	Very good
Working temperature, °C [max]	70	70	70	70	120	150	70	80	100

Type	B [mm]	A [mm]	P [mm]
Chevron R15/480	500	480	200
Chevron R15/480	550	480	200
Chevron R15/480	600	480	200
Chevron R15/480	650	480	200
Chevron R15/650	700	650	200
Chevron R15/650	750	650	200
Chevron R15/650	800	650	200

Characteristics of insertions

Type of insertions	EP 80	EP 100	EP 125	EP 160
Insertions number	2 - 4			
Tensile strength, Kgf/cm, min	160 - 240	200 - 400	250 - 500	315 - 630
Width [mm]	500 - 800			
Thickness [mm]	4 - 12	6 - 12	6 - 12	6 - 12

CHEVRON R15

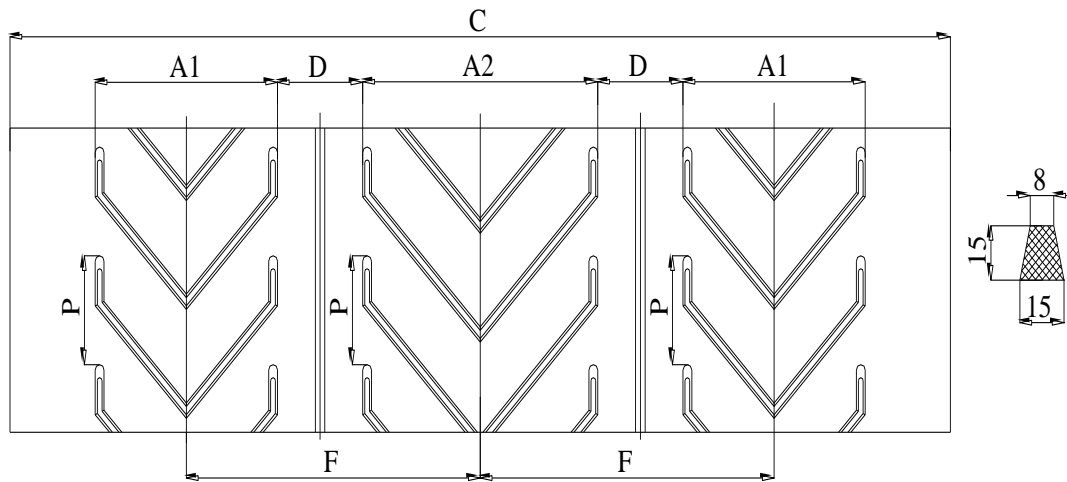

Type	C [mm]	A1 [mm]	A2 [mm]	P [mm]	D [mm]	F [mm]
Chevron R15/310	1350-1600	310	400	150	145	500

Rubber mixture, properties for covers	General use				Resistance to temperature		Resistance to oil		
	w	x	y	z	T2	T3	MOR	G	ROS
Tensile strength, daN/cm ² , min	180	250	200	150	150	120	150	140	150
Elongation at break, %, min	400	450	400	70	450	350	350	350	350
Abrasion resistance (volume of wear), mm ³ , max	90	120	150	250	150	200	200	200	150
Resistant to oil	No	No	No	No	No	No	Medium	Good	Very good
Working temperature, °C [max]	70	70	70	70	120	150	70	80	100

Characteristics of insertions

Type of insertions	EP 80	EP 100	EP 125	EP 160
Insertions number	2 - 4			
Tensile strength, Kgf/cm, min	160 - 240	200 - 400	250 - 500	315 - 630
Width [mm]	1350 - 1600			
Thickness [mm]	4 - 12	6 - 12	6 - 12	6 - 12

CHEVRON R15

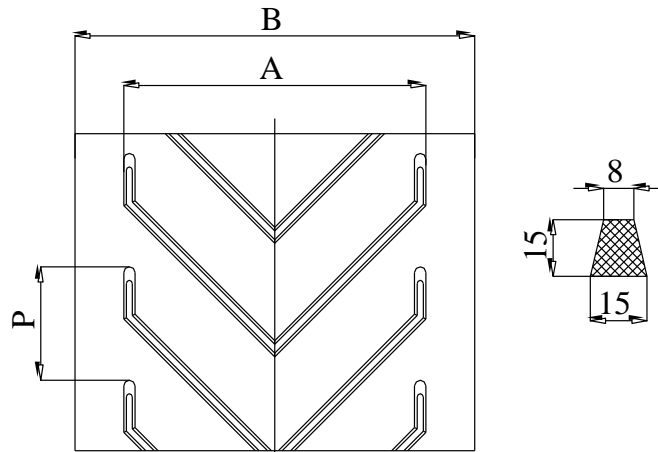

Type	B [mm]	A [mm]	P [mm]
Chevron R15/400	450	400	150
Chevron R15/400	500	400	150

Rubber mixture, properties for covers	General use				Resistance to temperature		Resistance to oil		
	w	x	y	z	T2	T3	MOR	G	ROS
Tensile strength, daN/cm ² , min	180	250	200	150	150	120	150	140	150
Elongation at break, % min	400	450	400	70	450	350	350	350	350
Abrasion resistance (volume of wear), mm ³ , max	90	120	150	250	150	200	200	200	150
Resistant to oil	No	No	No	No	No	No	Medium	Good	Very good
Working temperature, °C [max]	70	70	70	70	120	150	70	80	100

Characteristics of insertions

Type of insertions	EP 80	EP 100	EP 125	EP 160
Insertions number	2 - 4			
Tensile strength, Kgf/cm, min	160 - 240	200 - 400	250 - 500	315 - 630
Width [mm]	450 - 500			
Thickness [mm]	4 - 12	6 - 12	6 - 12	6 - 12

CHEVRON R15

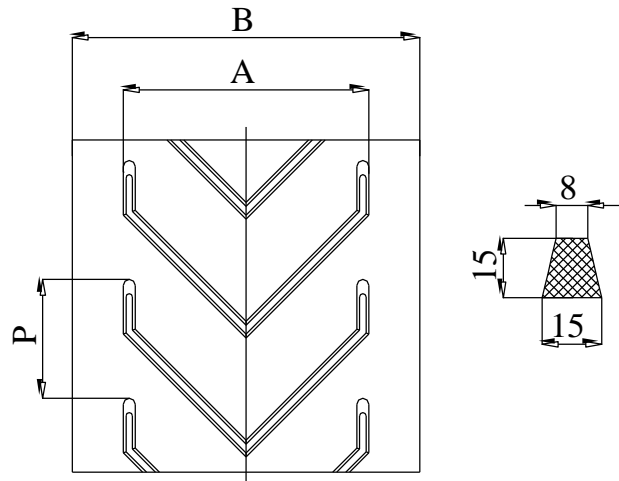

Type	B [mm]	A [mm]	P [mm]
Chevron R15/310	350	310	150
Chevron R15/310	400	310	150
Chevron R15/310	450	310	150
Chevron R15/310	500	310	150

Rubber mixture, properties for covers	General use				Resistance to temperature		Resistance to oil		
	w	x	y	z	T2	T3	MOR	G	ROS
Tensile strength, daN/cm ² , min	180	250	200	150	150	120	150	140	150
Elongation at break, % min	400	450	400	70	450	350	350	350	350
Abrasion resistance (volume of wear), mm ³ , max	90	120	150	250	150	200	200	200	150
Resistant to oil	No	No	No	No	No	No	Medium	Good	Very good
Working temperature, °C [max]	70	70	70	70	120	150	70	80	100

Characteristics of insertions

Type of insertions	EP 80	EP 100	EP 125	EP 160
Insertions number	2 - 4			
Tensile strength, Kgf/cm, min	160 - 240	200 - 400	250 - 500	315 - 630
Width [mm]	350 - 500			
Thickness [mm]	4 - 12	6 - 12	6 - 12	6 - 12

CHEVRON R15

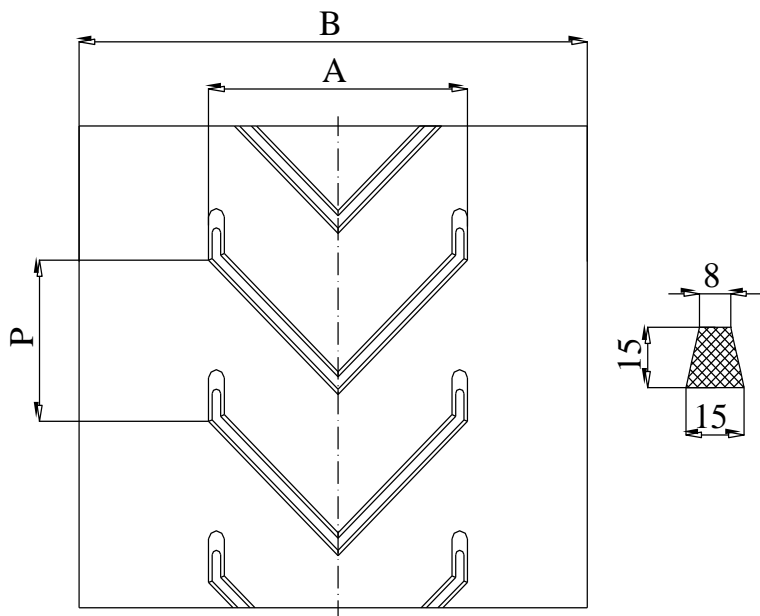

Rubber mixture, properties for covers	General use				Resistance to temperature		Resistance to oil		
	w	x	y	z	T2	T3	MOR	G	ROS
Tensile strength, daN/cm ² , min	180	250	200	150	150	120	150	140	150
Elongation at break, % min	400	450	400	70	450	350	350	350	350
Abrasion resistance (volume of wear), mm ³ , max	90	120	150	250	150	200	200	200	150
Resistant to oil	No	No	No	No	No	No	Medium	Good	Very good
Working temperature, °C [max]	70	70	70	70	120	150	70	80	100

Type	B [mm]	A [mm]	P [mm]
Chevron R15/250	300	250	200
Chevron R15/250	350	250	200
Chevron R15/250	400	250	200
Chevron R15/250	450	250	200
Chevron R15/250	500	250	200

Characteristics of insertions

Type of insertions	EP 80	EP 100	EP 125	EP 160
Insertions number	2 - 4			
Tensile strength, Kgf/cm, min	160 - 240	200 - 400	250 - 500	315 - 630
Width [mm]	300 - 500			
Thickness [mm]	4 - 12	6 - 12	6 - 12	6 - 12

CHEVRON R32

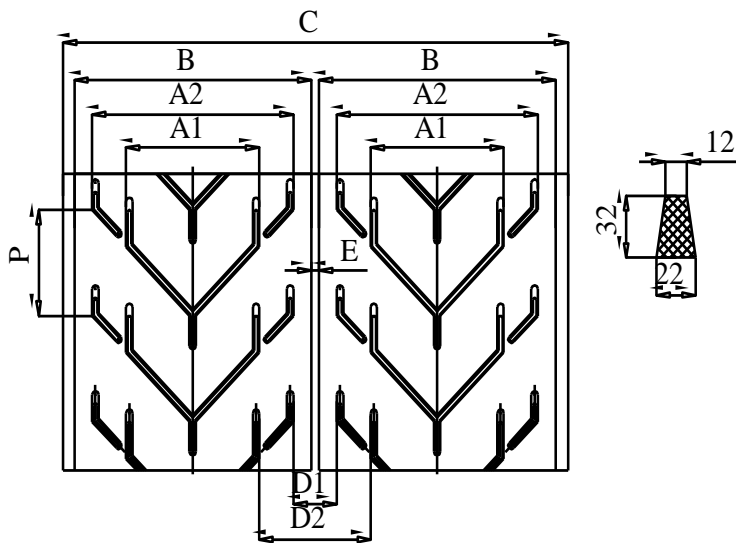

Type	C [mm]	B [mm]	A1 [mm]	A2 [mm]	P [mm]	D1 [mm]	D2 [mm]	E [mm]
Chevron R32/450	1300-1600	500-800	450	-	330	-	350	300 - 0
Chevron R32/680	1500-1600	700-800	450	680	330	120	350	100 - 0

Rubber mixture, properties for covers	General use				Resistance to temperature		Resistance to oil		
	w	x	y	z	T2	T3	MOR	G	ROS
Tensile strength, daN/cm ² , min	180	250	200	150	150	120	150	140	150
Elongation at break, % min	400	450	400	70	450	350	350	350	350
Abrasion resistance (volume of wear), mm ³ , max	90	120	150	250	150	200	200	200	150
Resistant to oil	No	No	No	No	No	No	Medium	Good	Very good
Working temperature, °C [max]	70	70	70	70	120	150	70	80	100

Characteristics of insertions

Type of insertions	EP 80	EP 100	EP 125	EP 160
Insertions number	2 - 4			
Tensile strength, Kgf/cm, min	160 - 240	200 - 400	250 - 500	315 - 630
Width [mm]	1300 - 1600			
Thickness [mm]	4 - 12	6 - 12	6 - 12	6 - 12

CHEVRON R32

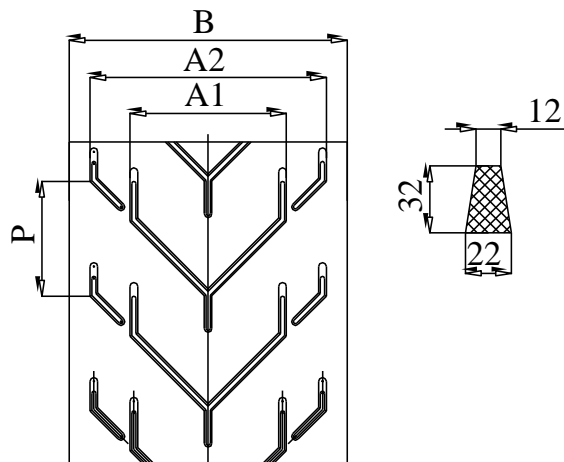

Rubber mixture, properties for covers	General use				Resistance to temperature		Resistance to oil		
	w	x	y	z	T2	T3	MOR	G	ROS
Tensile strength, daN/cm ² , min	180	250	200	150	150	120	150	140	150
Elongation at break, % min	400	450	400	70	450	350	350	350	350
Abrasion resistance (volume of wear), mm ³ , max	90	120	150	250	150	200	200	200	150
Resistant to oil	No	No	No	No	No	No	Medium	Good	Very good
Working temperature, °C [max]	70	70	70	70	120	150	70	80	100

Type	B [mm]	A1 [mm]	A2 [mm]	P [mm]
Chevron R32/450	500-800	450	-	330
Chevron R32/680	700-800	450	680	330

Characteristics of insertions

Type of insertions	EP 80	EP 100	EP 125	EP 160
Insertions number	2 - 4			
Tensile strength, Kgf/cm, min	160 - 240	200 - 400	250 - 500	315 - 630
Width [mm]	500 - 800			
Thickness [mm]	4 - 12	6 - 12	6 - 12	6 - 12

CHEVRON R32

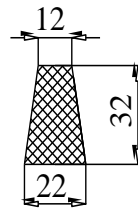
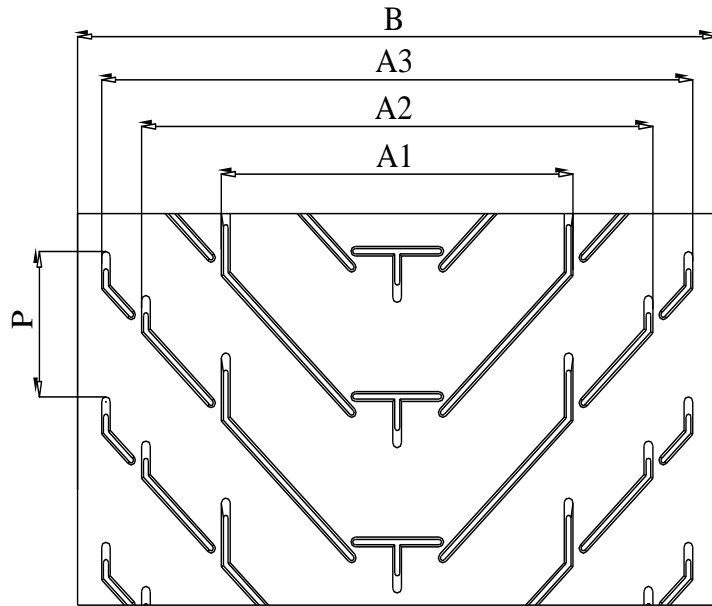

Rubber mixture, properties for covers	General use				Resistance to temperature		Resistance to oil		
	w	x	y	z	T2	T3	MOR	G	ROS
Tensile strength, daN/cm ² , min	180	250	200	150	150	120	150	140	150
Elongation at break, % min	400	450	400	70	450	350	350	350	350
Abrasion resistance (volume of wear), mm ³ , max	90	120	150	250	150	200	200	200	150
Resistant to oil	No	No	No	No	No	No	Medium	Good	Very good
Working temperature, °C [max]	70	70	70	70	120	150	70	80	100

Type	B [mm]	A1 [mm]	A2 [mm]	A3 [mm]	P [mm]
Chevron R32/880	900-1600	880	-	-	330
Chevron R32/1280	1300-1600	880	1280	-	330
Chevron R32/1480	1500-1600	880	1280	1480	330

Characteristics of insertions

Type of insertions	EP 80	EP 100	EP 125	EP 160
Insertions number	2 - 4			
Tensile strength, Kgf/cm, min	160 - 240	200 - 400	250 - 500	315 - 630
Width [mm]	900 - 1600			
Thickness [mm]	4 - 12	6 - 12	6 - 12	6 - 12

CHEVRON A33

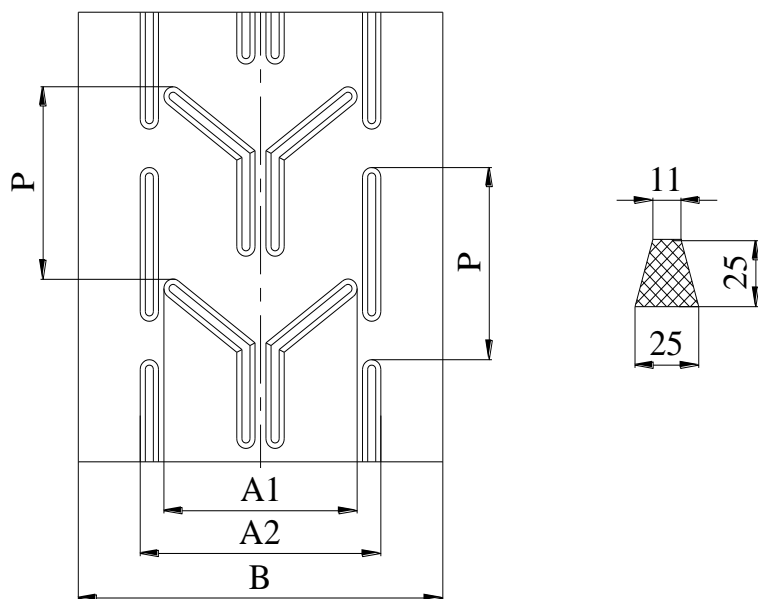

Rubber mixture, properties for covers	General use				Resistance to temperature		Resistance to oil		
	w	x	y	z	T2	T3	MOR	G	ROS
Tensile strength, daN/cm ² , min	180	250	200	150	150	120	150	140	150
Elongation at break, %, min	400	450	400	70	450	350	350	350	350
Abrasion resistance (volume of wear), mm ³ , max	90	120	150	250	150	200	200	200	150
Resistant to oil	No	No	No	No	No	No	Medium	Good	Very good
Working temperature, °C [max]	70	70	70	70	120	150	70	80	100

Characteristics of insertions

Type	B [mm]	A1 [mm]	A2 [mm]	P [mm]
Chevron A33 (R25/330)	400-750	265	330	250

Type of insertions	EP 80	EP 100	EP 125	EP 160
Insertions number	2 - 4			
Tensile strength, Kgf/cm, min	160 - 240	200 - 400	250 - 500	315 - 630
Width [mm]	400 - 750			
Thickness [mm]	4 - 12	6 - 12	6 - 12	6 - 12

CHEVRON A83

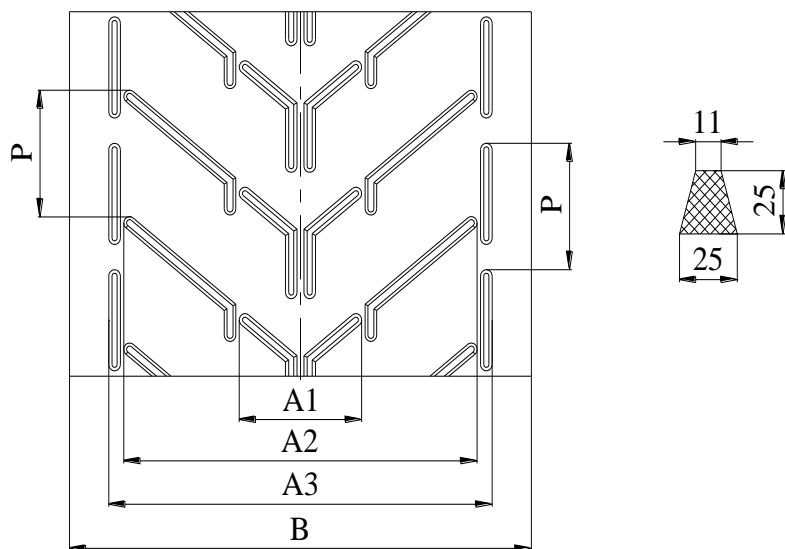

Rubber mixture, properties for covers	General use				Resistance to temperature		Resistance to oil		
	w	x	y	z	T2	T3	MOR	G	ROS
Tensile strength, daN/cm ² , min	180	250	200	150	150	120	150	140	150
Elongation at break, %, min	400	450	400	70	450	350	350	350	350
Abrasion resistance (volume of wear), mm ³ , max	90	120	150	250	150	200	200	200	150
Resistant to oil	No	No	No	No	No	No	Medium	Good	Very good
Working temperature, °C [max]	70	70	70	70	120	150	70	80	100

Characteristics of insertions

Type	B [mm]	A1 [mm]	A2 [mm]	A3 [mm]	P [mm]
Chevron A83 (R25/830)	900-1200	265	765	830	250

Type of insertions	EP 80	EP 100	EP 125	EP 160
Insertions number	2 - 4			
Tensile strength, Kgf/cm, min	160 - 240	200 - 400	250 - 500	315 - 630
Width [mm]	900 - 1200			
Thickness [mm]	4 - 12	6 - 12	6 - 12	6 - 12

CHEVRON A101

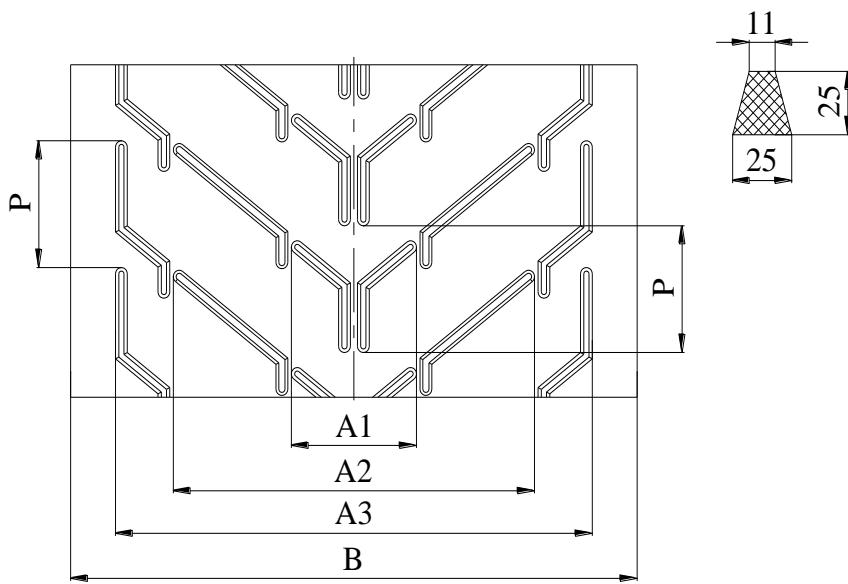

Type	B [mm]	A1 [mm]	A2 [mm]	A3 [mm]	P [mm]
Chevron A101 (R25/1010)	1100-1600	265	765	1010	250

Rubber mixture, properties for covers	General use				Resistance to temperature		Resistance to oil		
	w	x	y	z	T2	T3	MOR	G	ROS
Tensile strength, daN/cm ² , min	180	250	200	150	150	120	150	140	150
Elongation at break, %, min	400	450	400	70	450	350	350	350	350
Abrasion resistance (volume of wear), mm ³ , max	90	120	150	250	150	200	200	200	150
Resistant to oil	No	No	No	No	No	No	Medium	Good	Very good
Working temperature, °C [max]	70	70	70	70	120	150	70	80	100

Characteristics of insertions

Type of insertions	EP 80	EP 100	EP 125	EP 160
Insertions number	2 - 4			
Tensile strength, Kgf/cm, min	160 - 240	200 - 400	250 - 500	315 - 630
Width [mm]	1100 - 1600			
Thickness [mm]	4 - 12	6 - 12	6 - 12	6 - 12

CHEVRON A133

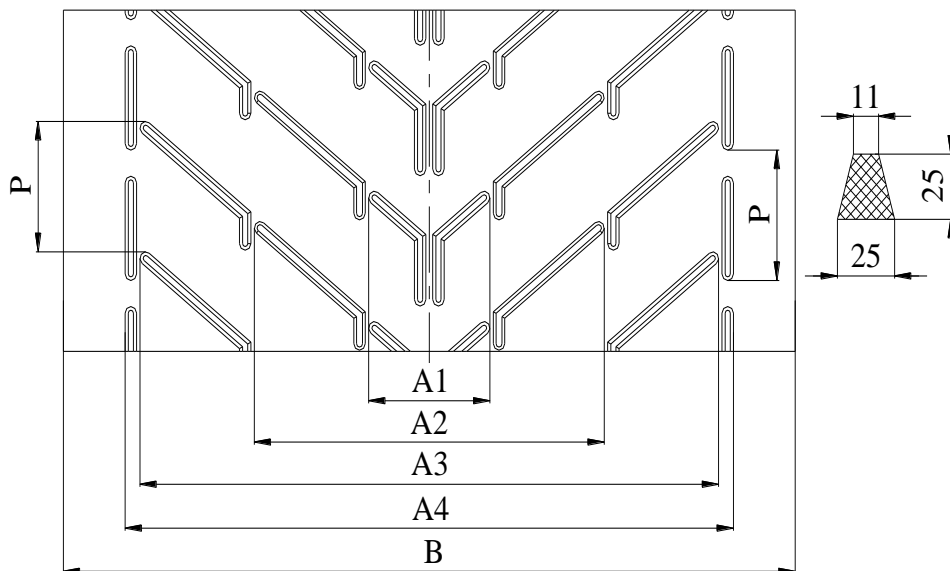

Rubber mixture, properties for covers	General use				Resistance to temperature		Resistance to oil		
	w	x	y	z	T2	T3	MOR	G	ROS
Tensile strength, daN/cm ² , min	180	250	200	150	150	120	150	140	150
Elongation at break, %, min	400	450	400	70	450	350	350	350	350
Abrasion resistance (volume of wear), mm ³ , max	90	120	150	250	150	200	200	200	150
Resistant to oil	No	No	No	No	No	No	Medium	Good	Very good
Working temperature, °C [max]	70	70	70	70	120	150	70	80	100

Characteristics of insertions

Type	B [mm]	A1 [mm]	A2 [mm]	A3 [mm]	A4 [mm]	P [mm]
Chevron A133 (R25/1330)	1400-1600	265	765	1265	1330	250

Type of insertions	EP 80	EP 100	EP 125	EP 160
Insertions number	2 - 4			
Tensile strength, Kgf/cm, min	160 - 240	200 - 400	250 - 500	315 - 630
Width [mm]	1400 - 1600			
Thickness [mm]	4 - 12	6 - 12	6 - 12	6 - 12